

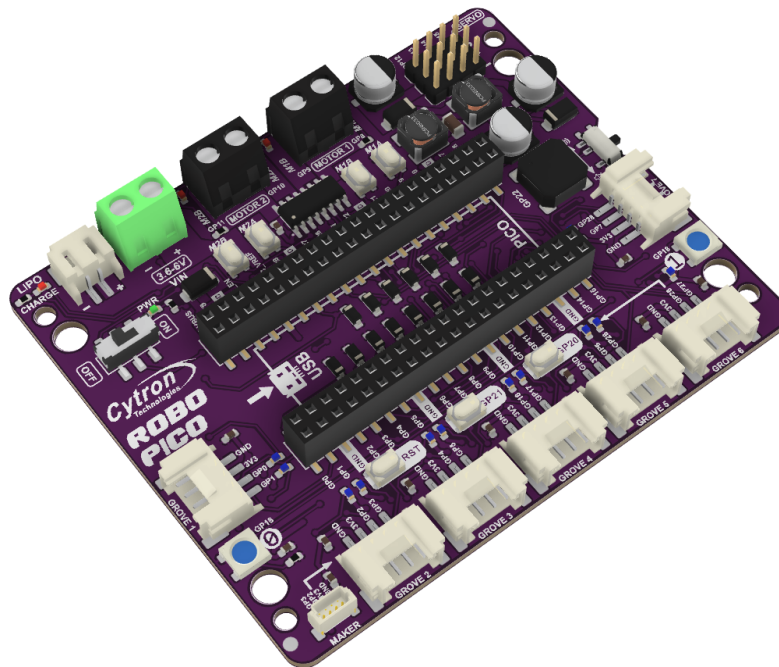

## ROBO PICO

**Simplifying Robotics with Raspberry Pi<sup>®</sup> Pico / Pico W**



## Datasheet

Rev 1.0  
April 2023

Information in this publication regarding device applications and the like is intended through suggestion only and may be superseded by updates. It is your responsibility to ensure that your application meets with your specifications. No representation or warranty is given and no liability is assumed by Cytron Technologies Incorporated with respect to the accuracy or use of such information or infringement of patents or other intellectual property rights arising from such use or otherwise. Use of Cytron Technologies's products as critical components in life support system is not authorized except with express written approval by Cytron Technologies. No licenses are conveyed, implicitly or otherwise, under any intellectual property rights.

*\* Raspberry Pi is a trademark of Raspberry Pi Ltd.*

## 1. BOARD LAYOUT & FUNCTION

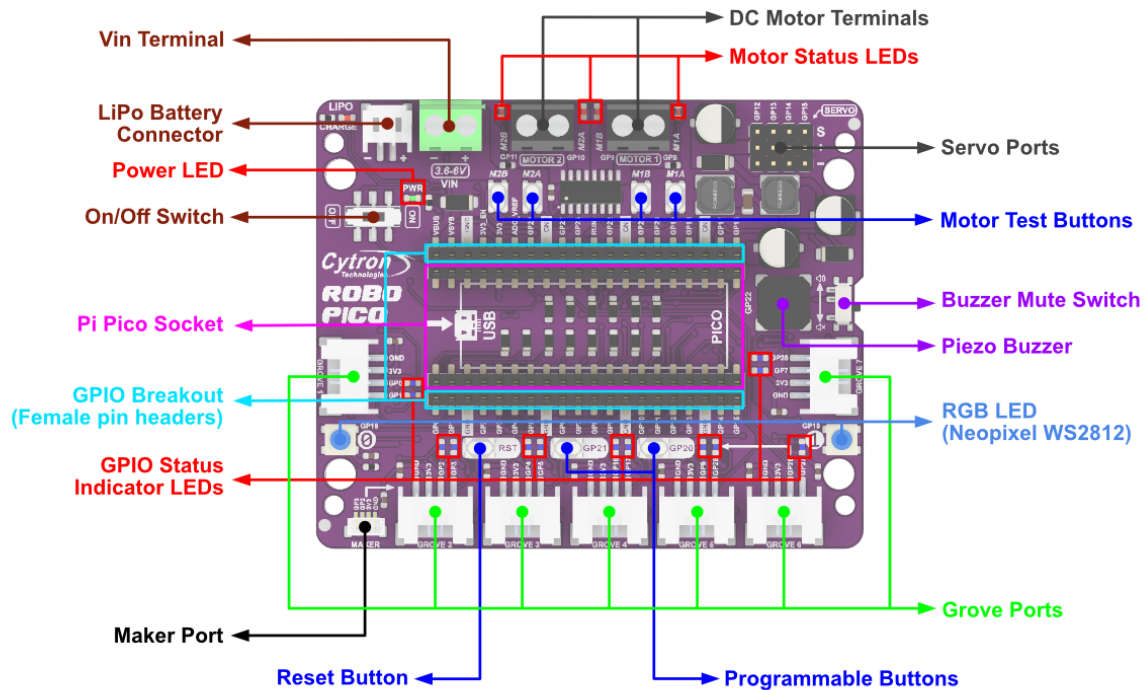

Figure 1: ROBO-PICO Board Functions

Function	Description
Vin Terminal	Connect to any power source within 3.6 - 6V.
LiPo Battery Connector	Connect to Single Cell LiPo / Li-Ion Battery The battery is rechargeable via USB port on the Raspberry Pi Pico / Pico W. <i>* The battery is protected from overcharged and over discharged. If the board cannot be turned on when the battery is connected, please charge the battery to activate the battery protection circuit.</i>
Power LED	Turn on when powered up.
On/Off Switch	Turn on/off the power, including the Raspberry Pi Pico.
Reset Button	Press to reset the Raspberry Pi Pico or Pico W.
GPIO Breakout	Female Pin Headers Breakout of the Raspberry Pi Pico or Pico W GPIO pins.

Function	Description																																																																																																		
<b>Grove Ports</b>	Connect to external Grove modules.																																																																																																		
	<table border="1"> <thead> <tr> <th>Grove Port</th> <th>GPIO</th> <th>PWM</th> <th>SPI</th> <th>I2C</th> <th>UART</th> <th>Analog</th> </tr> </thead> <tbody> <tr> <td rowspan="2">1</td> <td>0</td> <td>PWM0-A</td> <td>SDIO</td> <td>SDA0</td> <td>TX0</td> <td>-</td> </tr> <tr> <td>1</td> <td>PWM0-B</td> <td>CSn0</td> <td>SCL0</td> <td>RX0</td> <td>-</td> </tr> <tr> <td rowspan="2">2</td> <td>2</td> <td>PWM1-A</td> <td>SCK0</td> <td>SDA1</td> <td>-</td> <td>-</td> </tr> <tr> <td>3</td> <td>PWM1-B</td> <td>SDO0</td> <td>SCL1</td> <td>-</td> <td>-</td> </tr> <tr> <td rowspan="2">3</td> <td>4</td> <td>PWM2-A</td> <td>SDIO</td> <td>SDA0</td> <td>TX1</td> <td>-</td> </tr> <tr> <td>5</td> <td>PWM2-B</td> <td>CSn0</td> <td>SCL0</td> <td>RX1</td> <td>-</td> </tr> <tr> <td rowspan="2">4</td> <td>16</td> <td>PWM0-A</td> <td>SDIO</td> <td>SDA0</td> <td>TX0</td> <td>-</td> </tr> <tr> <td>17</td> <td>PWM0-B</td> <td>CSn0</td> <td>SCL0</td> <td>RX0</td> <td>-</td> </tr> <tr> <td rowspan="2">5</td> <td>6</td> <td>PWM3-A</td> <td>SCK0</td> <td>SDA1</td> <td>-</td> <td>-</td> </tr> <tr> <td>26</td> <td>PWM5-A</td> <td>-</td> <td>SDA1</td> <td>-</td> <td>ADC0</td> </tr> <tr> <td rowspan="2">6</td> <td>26</td> <td>PWM5-A</td> <td>-</td> <td>SDA1</td> <td>-</td> <td>ADC0</td> </tr> <tr> <td>27</td> <td>PWM5-B</td> <td>-</td> <td>SCL1</td> <td>-</td> <td>ADC1</td> </tr> <tr> <td rowspan="2">7</td> <td>7</td> <td>PWM3-B</td> <td>SDO0</td> <td>SCL1</td> <td>-</td> <td>-</td> </tr> <tr> <td>28</td> <td>PWM6-A</td> <td>-</td> <td>-</td> <td>-</td> <td>ADC2</td> </tr> </tbody> </table>	Grove Port	GPIO	PWM	SPI	I2C	UART	Analog	1	0	PWM0-A	SDIO	SDA0	TX0	-	1	PWM0-B	CSn0	SCL0	RX0	-	2	2	PWM1-A	SCK0	SDA1	-	-	3	PWM1-B	SDO0	SCL1	-	-	3	4	PWM2-A	SDIO	SDA0	TX1	-	5	PWM2-B	CSn0	SCL0	RX1	-	4	16	PWM0-A	SDIO	SDA0	TX0	-	17	PWM0-B	CSn0	SCL0	RX0	-	5	6	PWM3-A	SCK0	SDA1	-	-	26	PWM5-A	-	SDA1	-	ADC0	6	26	PWM5-A	-	SDA1	-	ADC0	27	PWM5-B	-	SCL1	-	ADC1	7	7	PWM3-B	SDO0	SCL1	-	-	28	PWM6-A	-	-	-	ADC2
	Grove Port	GPIO	PWM	SPI	I2C	UART	Analog																																																																																												
	1	0	PWM0-A	SDIO	SDA0	TX0	-																																																																																												
		1	PWM0-B	CSn0	SCL0	RX0	-																																																																																												
	2	2	PWM1-A	SCK0	SDA1	-	-																																																																																												
		3	PWM1-B	SDO0	SCL1	-	-																																																																																												
	3	4	PWM2-A	SDIO	SDA0	TX1	-																																																																																												
		5	PWM2-B	CSn0	SCL0	RX1	-																																																																																												
	4	16	PWM0-A	SDIO	SDA0	TX0	-																																																																																												
		17	PWM0-B	CSn0	SCL0	RX0	-																																																																																												
	5	6	PWM3-A	SCK0	SDA1	-	-																																																																																												
		26	PWM5-A	-	SDA1	-	ADC0																																																																																												
6	26	PWM5-A	-	SDA1	-	ADC0																																																																																													
	27	PWM5-B	-	SCL1	-	ADC1																																																																																													
7	7	PWM3-B	SDO0	SCL1	-	-																																																																																													
	28	PWM6-A	-	-	-	ADC2																																																																																													
<b>Maker Port</b>	Compatible with QWIIC / Stemma QT / Grove (with conversion cable). <i>* The pins are shared with the Grove 2 port (GPIO 2, 3).</i>																																																																																																		
<b>NeoPixel RGB LEDs</b>	User programmable NeoPixel RGB LED. Connected to GP18.																																																																																																		
<b>Programmable Buttons</b>	Accessible from the user program. Connected to GP20 and GP21																																																																																																		
<b>Piezo Buzzer</b>	Can be used to play tone or melody. Connected to GP22.																																																																																																		
<b>Buzzer Mute Switch</b>	Used to mute the piezo buzzer.																																																																																																		
<b>Status LEDs</b>	LED indicators for Raspberry Pi Pico GPIOs on Grove Ports. Turn on when the GPIO state is high.																																																																																																		
<b>Motor Test Buttons</b>	Press to test the functionality of the motor driver. Motor will run at full speed. <ul style="list-style-type: none"> <li>● MxA : Forward*</li> <li>● MxB : Backward*</li> </ul>																																																																																																		
<b>Servo Ports</b>	Connectors for 4 x RC servo motors. Signal is connected to GP12, GP13, GP14 and GP15. V+ voltage is equal to power source voltage.																																																																																																		
<b>Motor Status LEDs</b>	Turn on when the motor is running. <ul style="list-style-type: none"> <li>● MxA : Forward*</li> <li>● MxB : Backward*</li> </ul>																																																																																																		

Function	Description
DC Motor Terminals	Connect to the motor terminal. Motor voltage at full speed is equal to power source voltage. Motor direction is dependent on the polarity. <ul style="list-style-type: none"> <li>● M1A : GP8            ● M2A : GP10</li> <li>● M1B : GP9           ● M2B : GP11</li> </ul>
VBAT Sense	Solder the jumper on the back of the board to allow voltage measurement of the VBAT via GP-28-ADC2. $V_{ADC2} = V_{BAT} / 2$ (VBAT = VIN or VUSB or VLiPo whichever is higher)
Pi Pico Socket	Socket for Raspberry Pi Pico and Pico W.

*Table 1: ROBO-PICO Board Functions*

\* *Actual motor direction is dependent on the motor connection.  
 Swapping the connection (MxA & MxB) will reverse the direction.*

## 2. RASPBERRY PI PICO PINOUT DIAGRAM

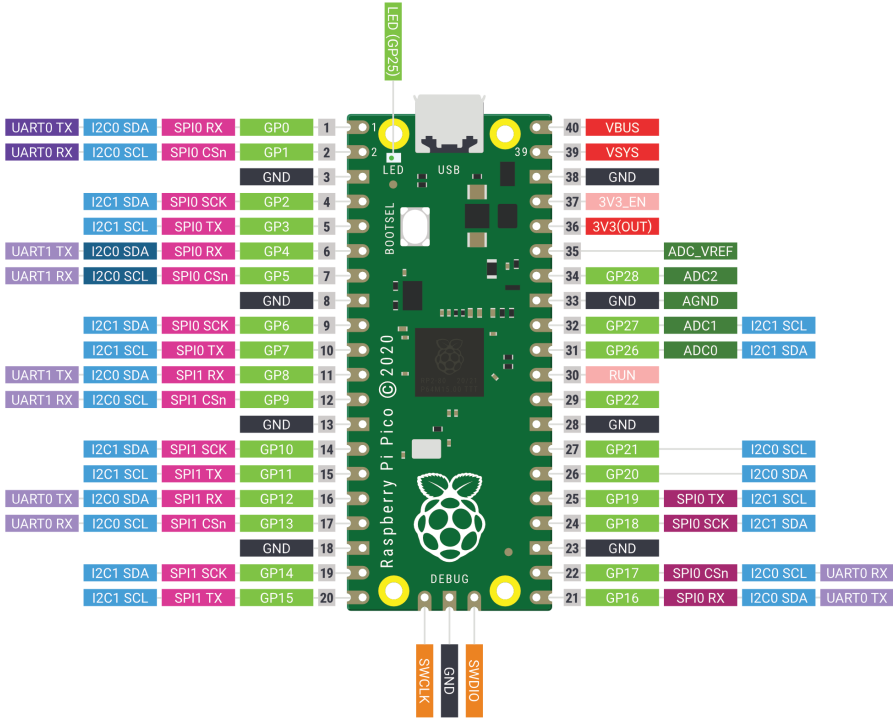

Figure 2: Raspberry Pi Pico Pinout Diagram

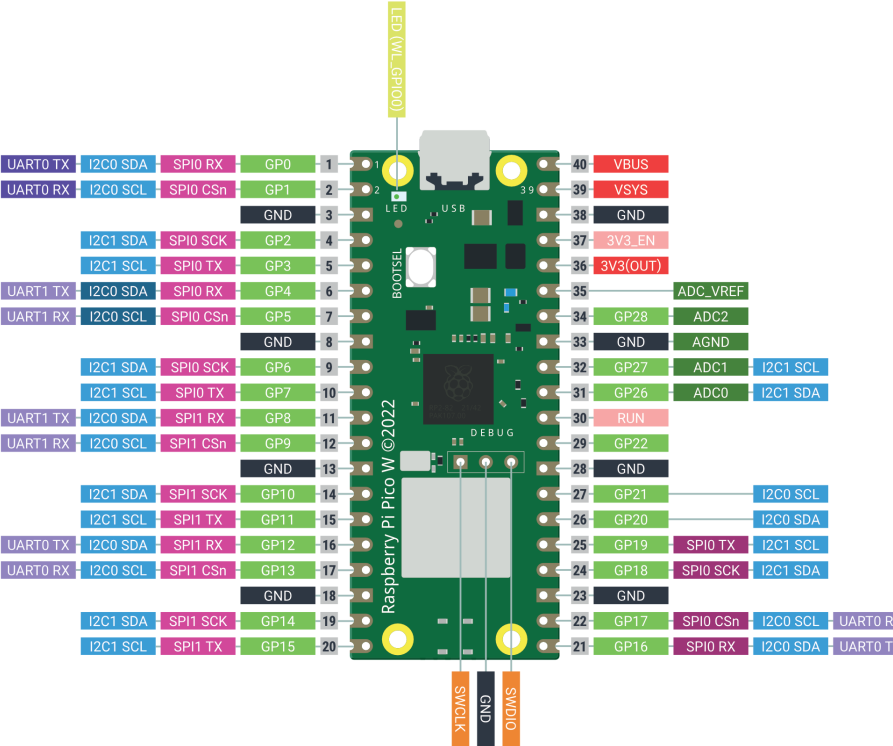

Figure 3: Raspberry Pi Pico W Pinout Diagram

### 3. SPECIFICATIONS

No	Parameters	Min	Max	Unit	
1	Power Input Voltage (USB, LiPo or VIN) *	3.6	6	V	
2	Digital Input Voltage	Low Level	-0.3	0.8	V
		High Level	2.0	3.6	V
3	Digital Output Voltage	Low Level	0	0.5	V
		High Level	2.6	3.3	V
4	Analog Input Voltage	0	3.3	V	
5	Vmotor & Vservo (Only USB is connected)	VUSB - 0.4		V	
6	Vmotor & Vservo (Only either one of LiPo or VIN is connected)	VLiPo or VIN		V	
7	Vmotor & Vservo (USB and LiPo are connected)	VUSB - 0.4		V	
8	Vmotor & Vservo (USB and VIN are connected)	VIN < VUSB	VUSB - 0.4		V
		VIN > VUSB and VIN - VUSB < 0.6	VIN - 0.4		V
		VIN - VUSB > 0.6	VIN		V
9	Maximum DC Motor Current (Per Channel)	Continuous	-	1	A
		Peak (< 5 seconds)	-	1.5	A
10	DC Motor Driver PWM Frequency	-	20	kHz	
11	Total +3V3 Output Current (Grove Ports)	-	300	mA	
12	Operating Temperature	-20	85	°C	

*Table 2: ROBO-PICO Absolute Maximum Ratings*

- \* Voltage for the DC motor and servo is equal to power input voltage.
- \* It's not recommended to connect both LiPo and VIN at the same time.  
 Although it's perfectly safe to do so.

## 4. MOTOR DRIVER TRUTH TABLE

Input A (GP8 / GP10)	Input B (GP9 / GP11)	Output A (M1A / M2A)	Output B (M1B / M2B)	Motor
Low	Low	Low	Low	Brake
High	Low	High	Low	Forward*
Low	High	Low	High	Backward*
High	High	Hi-Z (Open)	Hi-Z (Open)	Coast

Table 3: Motor Driver Truth Table

\* Actual motor direction is depending on the motor connection.  
 Swapping the connection (MA & MB) will reverse the direction.

## 5. DIMENSION

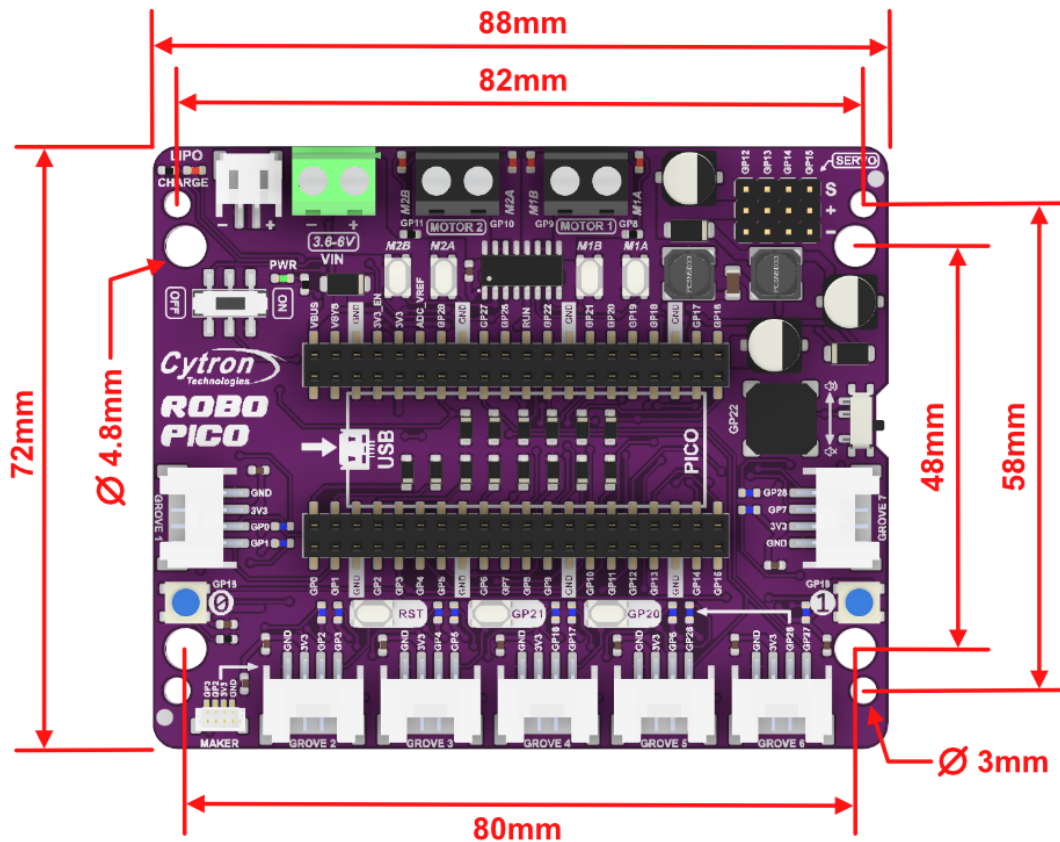

Figure 4: ROBO-PICO Dimension



*Prepared by:*

***Cytron Technologies Sdn Bhd***

[www.cytron.io](http://www.cytron.io)

No. 1, Lorong Industri Impian 1,  
Taman Industri Impian,  
14000 Bukit Mertajam,  
Penang, Malaysia.

*Tel:* +604 - 548 0668

*Fax:* +604 - 548 0669

*Email:*

[support@cytron.io](mailto:support@cytron.io)

[sales@cytron.io](mailto:sales@cytron.io)